

INSTALLATION INSTRUCTIONS for GSM-18V3

1. **Important !** It is a must to read the instructions before installing and programming the unit.

2. Insert the Sim Card

If you are using your own Sim card, make sure that the Sim card does not have **any data or phone numbers** in its memory. The Sim card must be cleared from any phone numbers prior to use with the GSM-18 unit. **YOU MUST MAKE SURE** and call the mobile phone network you are registered with, **and cancel the Message Bank and the Call Back Notification service on your Sim card.**

Insert the Sim card by opening the small window on top of the GSM-18 unit.

Note !

Make sure that you insert or remove the Sim card only when the unit is disconnected from the Power.

3. Installation

First connect the Antenna, Speaker, Microphone and the Push Button's wires according to the diagram below:

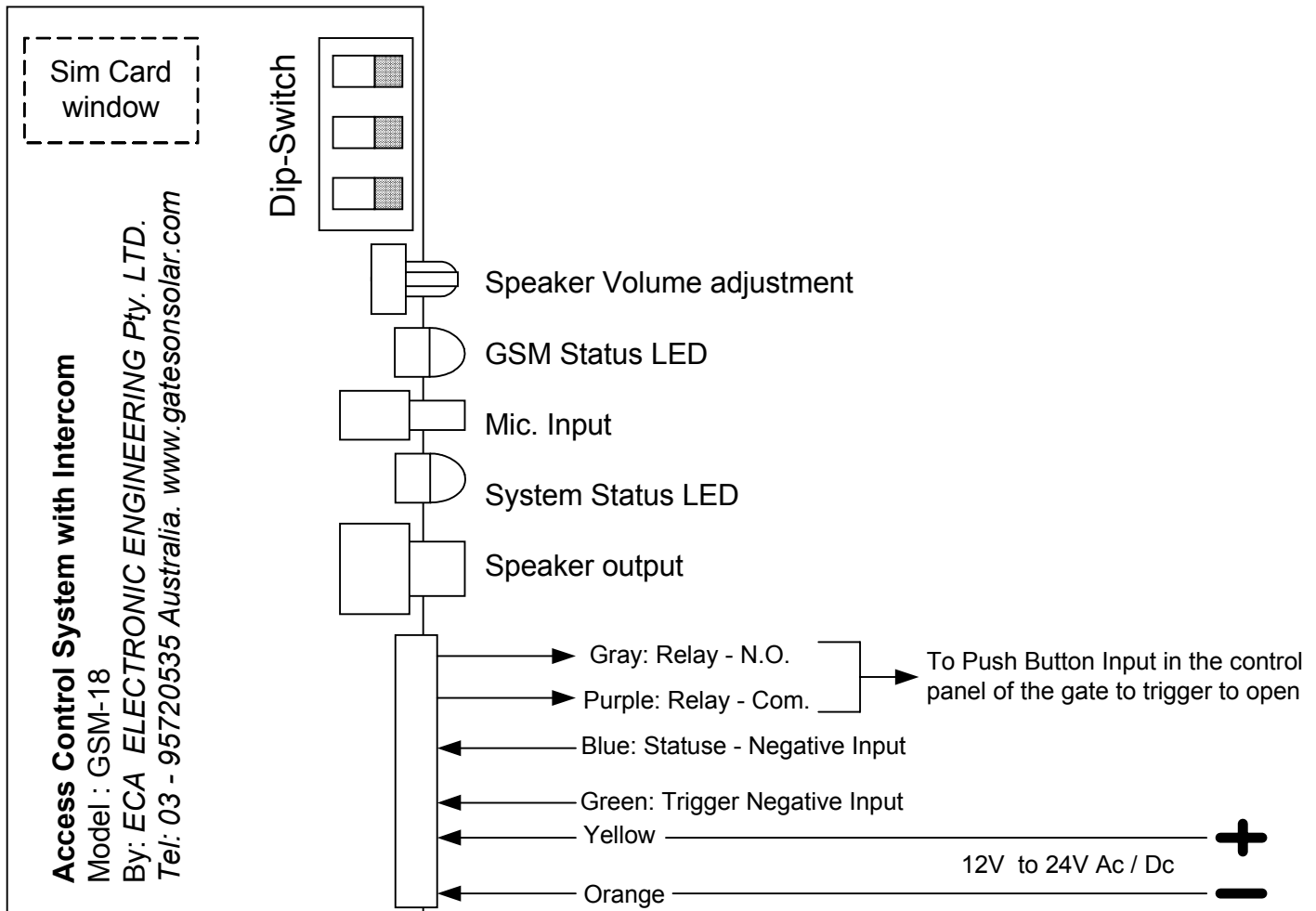

DipSw No.	Application	ON	OFF
1	Programming Mode	Enable	Disable
2	Operation Mode	Automatic	Learning Mode
3	Relay output operation function	Latch	Pulse

4. Antenna

Make sure to install the GSM antenna as high as possible and do not fold the excessive wire of the antenna.

5. Power

The unit can operate with voltage between 12V to 24V AC or DC by the Orange and Yellow wires of the unit. If DC power is used, the **yellow** wire is the **Negative** and the **Orange** wire is the **Positive**.

Wait 25 seconds for the unit to set up after connecting the power. The GSM and Status LEDs will start to flash when the system is ready.

6. Memory

The unit can be programmed with **1000 phone numbers** to become as *authorized users*. The system will respond or answer (according to the settings – see below) to the call of authorized users only and hang-up on unauthorized calls.

7. Output

The Grey and Purple wires of the unit are the internal relay's output connections COM & N.O. that can be used to activate any gate, garage door or alarm. Use the Grey (Com.) and the Purple (N.O.) wires in the unit to trigger the control panel of the appliance.

8. Relay's Function

You can select one out to two functions for the internal relay to activate the external control panel by:

Dip – Switch # 3 : OFF => Pulse function or ON => Latch function

9. PROGRAMM MODE

In Program Mode you can:

- Add or delete users' phone numbers.
- Lock and Unlock the system by the MASTER number.

Entering PROGRAM MODE:

1. Set **DIP-SWITCH # 1** to **ON** position to enable entering Program Mode.
2. Dial the unit's Sim Card phone number from any phone.
After the first ring, the unit will answer the call with a long "Beep" sound and wait for your programming instructions.
3. First you need to *clear* the memory of the Sim card from any data and phone numbers.
For **DELETING** all the phone numbers in the unit's memory **except the MASTER phone number;**

Press * + **4** + * + * + * + # => a long beep to confirm.

4. Master Phone Number

Program-in the **Master Phone Number (MPN)** that will enable you to make all the programming features (from this phone number only) without the need of accessing the unit in the future.

Please Note!

The **MPN** can enter Program Mode without setting Dipswitch #1 on in the unit. The unit will always answer the Master phone number and automatically enter programming mode, **even if the Dip Switch No. 1 is OFF.**

For programming the **MASTER** Phone Number:

Press **000** + * + **phone number** + # => a long beep to confirm.

The unit will announce the phone number after programming to confirm.

5. **Programming Users' Phone Numbers (UPN)**

Program-in up to 1000 phone numbers (Users' Phone Numbers) to activate the unit's relay with their phones.

For programming the **FIRST Phone Number**:

Press **001 + * + phone number + #** => a long beep to confirm.

Note: The unit will announce the phone number after each programming to confirm.

For programming the **SECOND Phone Number**:

Press **002 + * + phone number + #** => a long beep to confirm.

,

,

For programming the **999th Phone Number**:

Press **999 + * + phone number + #** => a long beep to confirm.

TO EXIT Program Mode :

Press *** + 0 + #** => the unit will exit Program Mode and hang up.

Please Note !

- The unit will automatically hang up if no response is received within 1 minute during programming.
- Do not forget to turn OFF Dipswitch No. 1 after existing program mode.
- During the programming mode, an invalid command will be indicated by two short beeps.

In Program Mode you also can:

6. **To DELETE** a specific *known phone number* from the memory do as follows:

Press *** + 4 + "The phone number you want to delete" + #** => a long beep to confirm.

7. **For DELETING** all the phone numbers **except the MASTER phone number**;

Press *** + 4 + * + * + * + #** => a long beep to confirm.

Note ! For deleting the MPN you must enter a new MASTER Phone Number only.

8. For getting the next available empty memory cell number or the number of UPNs in the unit:

Press * + 1 + # => The system will announce the next empty cell number by saying individual numbers; i.e. If the next empty memory cell is Cell Number "026" the system will say: Zero , Two , Six

9. In program mode you can activate the output relay (according to the Function chosen) by :

Press *** + 5 + #** => a long beep to confirm.

10. **SECURITY LOCK**

The unit will enter program mode automatically when the "master" number calls and allows the user to lock or unlock the unit as follows:

To **LOCK** the system: Press *** + 2 + #** => a long beep to confirm

To **UNLOCK** the system: Press *** + 3 + #** => a long beep to confirm .

11. Operation Mode

The unit can operate in one out of two operation modes: *Automatic* or *Learning Mode* selected by:

Dip – Switch # 2 : ON => AUTOMATIC MODE or OFF => LEARNING MODE

AUTOMATIC MODE:

If Automatic Mode is chosen (by Dip-Sw. # 2 => ON) then:

The unit will never answer any incoming calls except to the “ MASTER ” phone number. If the calling phone number is an authorized user (is one of the 1000 phone numbers programmed into the memory) then the unit will operate the relay output in the unit according to the function chosen by the DIP-SWITCH # 3 (Latch or Pulse) and **hang-up on the incoming call without answering it.** If the caller is not a valid phone number, then the unit will reject the call and hang-up on the call immediately.

LEARNING MODE:

It is inconvenient and time consuming to teach many Users’ phone numbers in to the system, therefore, this mode was provided to enable easier way of programming big numbers of UNPs.

If “Learning Mode” is chosen (by Dip-Sw. # 2 => OFF) then:

The unit will not answer any of the incoming calls and automatically register each of the incoming phone numbers in to the memory of the unit and activate the relay output in the unit according to the function chosen by the DIP-SWITCH # 3 (Latch or Pulse).

Choose this mode to register all the UNPs in to the system in the first two-there days and then turn off dip switch # 2 and change the operation mode to “Automatic”, so that no other numbers will be automatically register in.

12. TRIGGER & STATUS Inputs

The unit has a negative **TRIGGER** input (the Green wire) to activate the microphone and speaker of the unit as an intercom system.

When the unit is triggered, the unit will announce in the speaker:

”PLEASE WAIT - YOUR CALL WILL BE ANSWERED SHORTLY”

Then, it will dial the first Phone Number and wait for an answer. If the call is not answered within 45 seconds, the GSM-18 will hang up and dial the second number programmed into the memory. The system will try the third number and then stop. When the call is answered by one of the three first numbers, the user can talk with the caller immediately until he hangs up.

During the time of speaking, the user (the person who answers the call) can activate the output relay (according to the FUNCTION chosen in the unit) while pressing the “ # “ key on his handset. The user can activate the output relay as many times as he wishes till he hangs up.

In this mode the end user can also check the situation of the gate (open or closed) if the **STATUS** input was connected to the gate by a magnet read switch.

To check the **STATUS** input press the “ * ” button on the hand set.

When the gate is close (STATUS input is “closed loop” to negative) then the unit will say “**THE GATE IS CLOSED**”, and if this input is “open” the unit will say “ **THE GATE IS OPEN**”.

In program mode the STATUS input could be checked (if it is a CLOSE LOOP or an OPEN LOOP) as follows:

Press * + 6 + # => One long beep to confirm CLOSE and two long beeps to confirm OPEN.